

DP10GS

Basic system 10 W

The DP10GS end-pumped high-end system is ideal for use when optimal laser beam quality and performance are required.

The system is especially suitable in the field of ID card and passport personalisation, in particular for the marking of ID cards with grey scale images, as well as for lacquer removal to create day and night design.

Advantages

- Output power 10 Watt (CW)
- Excellent laser beam quality and pulse-to-pulse stability
- Single-phase mains connection
- Air-cooled
- Long working life of the laser diodes means little servicing



DP 10GS

Basic system 10 W

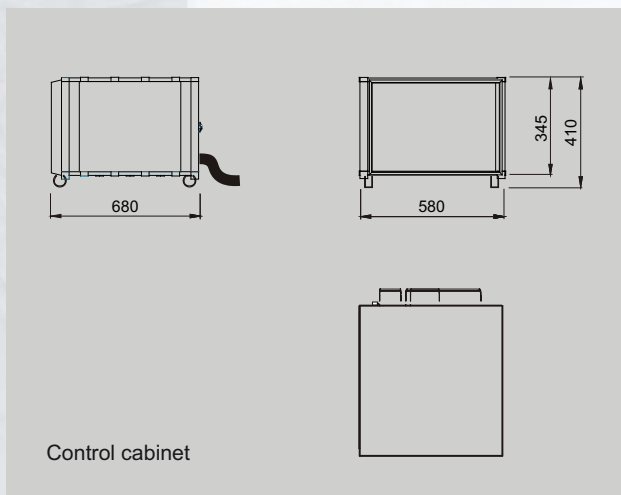
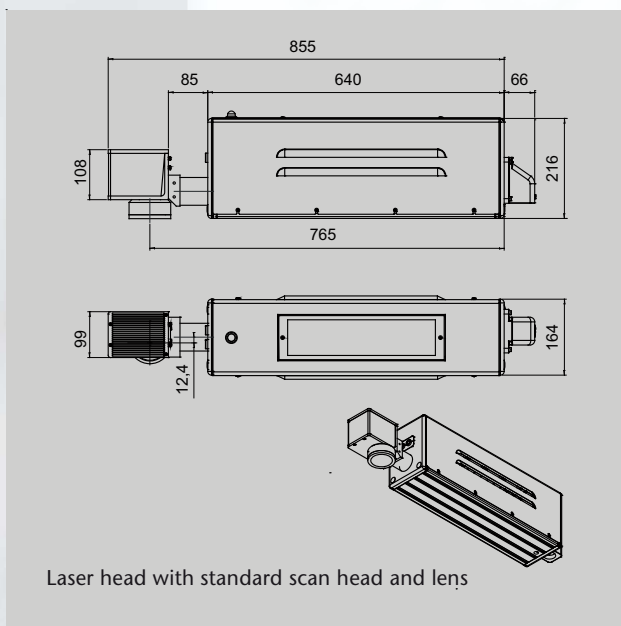

System

Marking field	110 x 110 mm ² (f=160 mm)
Marking speed	up to 5000 mm/s up to 500 characters/s
Line width	typically 55 µm

Laser

Laser type	Nd:YVO ₄ , 1064 nm, diode pumped
Power (CW)	typically 10 W
(QS)	typically 10 kW/pulse (30 kHz)
Power stability	+/- 1 % (CW) +/- 1.5 % (QS)
Output modes	Continuous wave operation (CW) Pulsed operation (QS, 10 - 100 kHz) Mixed operation (parameterizable)
Pulse energy	0.5 mJ (10 kHz)
Pulse width	30 ns (30 kHz)

Control

PC	CompactPCI-PC
Operating system	MS Windows XP
Laser control	FOBAGRAF with Import functions of plt/dwg/dxf/ai/jpg/tif/pcx/bmp ...
Interfaces	serial, digital I/O, Ethernet, USB, Profibus

Installation

Electrical	1/N/PE, AC 110-230 V, ± 10%, 50/60 Hz
Power consumption	typically 1.0 kW
Cooling	Air
Temperature	15 - 38 °C
Humidity	90 % (up to max. 20 °C) 30 % (up to max. 38 °C) non-condensing
Weight	Laser head approx. 15 kg ¹⁾ Control cabinet approx. 60 kg
Degree of protection	Control cabinet IP43 Laser head IP 20
Safety	Class IV Laser

Options

Marking on the fly	for marking moving workpieces
19"-Racks	for integration
Changeable lens	100 mm/163 mm/254 mm/420 mm
High-speed-scan heads	

¹⁾ without F-Theta lens

FOBA®

Laser Marking + Engraving

A Virtek Company

EUROPE

FOBA Technology + Services GmbH
www.foba.de
sales@foba.de

Altenaer Straße 170
D-58513 Lüdenscheid
Germany

Tel. +49 23 51 996-0
Fax +49 23 51 996-155

NORTH & SOUTH AMERICA

Virtek
www.foba.ca
fobasales@virtek.ca

785 Bridge Street
Waterloo, ON N2V 2K1
Canada

Tel. +1 800 684-7835 or 519 746-7190
Fax +1 519 746-3383